

# *Encounters with the Force of Herbert A. Simon*

*David Klahr*

---

In high-energy physics, one standard method for determining the properties of a particle is to examine its influence on other particles, whether through attraction, repulsion, absorption, deflection, fission, or fusion. Analogously, in the domain of human interactions, it is possible to infer some of the characteristics of a man by examining the nature of his impact on those who felt the force of his mind and his character.

As evidenced by the volume you hold in your hands, Herb Simon's diverse, profound, and multi-faceted interactions with the authors of these chapters, as well as with hundreds of other people, produced life trajectories vastly different from what they would have been otherwise. Herb's influence came in a variety of forms: personal, scientific, intellectual, institutional, and political. In some chapters, the account of Herb's impact is either implicit or abstract. In this chapter, the story will be explicit, direct, and personal. This approach is not without its hazards, because it could be construed as inappropriately self-centered in a volume intended to honor and acclaim one of the most important thinkers of the twentieth century. Let me acknowledge at the outset then, that while I gratefully acknowledge Herb's immense influence on me, I am humbled by realizing what a small fraction of his attention or energy it consumed.

### *Action at a Distance*

Herb's first influence on me could be viewed as "action at a distance." I had been advised, as an undergraduate engineer with an interest in computers, to read some recent (in 1959) papers in a new area called "heuristic problem solving" (Newell and Simon 1956; Newell, Shaw, and Simon 1958; Simon and Newell 1958) in order to get some ideas on how to advance my senior thesis project aimed at creating a FORTRAN program that learned how to play a game. This was my first encounter with what would eventually be called "cognitive science" and with the (then) startling proposal that thinking was a process of symbolic computation.

### *Attraction*

A few years later, I decided that, although I enjoyed working with computers, I wanted to get an MBA. I was advised that the only B-school in the world that could also teach me something about "thinking machines" was the Graduate School of Industrial Administration (GSIA) at (then) Carnegie Tech. Thus, Herb's second influence was to attract not only my attention, but also my physical presence to the center of the intellectual webs he was beginning to spin at Carnegie Tech.

In 1962, when I arrived, GSIA was a powerhouse of exciting new ideas in economics,<sup>1</sup> organization theory, managerial decision making, AI, and cognitive psychology. I was dazzled by Herb's work on mathematical social psychology (recasting classic propositions about economic decision making, group interaction, etc. in terms of simultaneous differential equations). I was also exposed to the innovative approaches of March and Simon (1958) and Cyert and March (1963) to the area of Organizations and Social Behavior (as it was called within GSIA at the time). I was excited to find that the same mathematics that I had learned in my undergraduate engineering courses could be

applied to the formulation of models of human behavior. Determined to sit at the foot of the throne, within a year I had transferred from the Masters program to the Ph.D. program and persuaded Herb to be my dissertation advisor.

### *Charged States*

Sometimes the smallest action by one actor in a dynamic system has an enormous influence on another actor. In my case, the little action with a huge impact occurred when Herb asked me, during one of our weekly meetings, to take a look at a paper that he was preparing on problem representation. After reading it carefully, I returned a few days later—not without some trepidation—to show Herb my comments. I was relieved when he seemed quite pleased (well, maybe not “quite pleased,” but at least not annoyed) with my suggestions, and I was delighted, several months later, when I saw the final version of the manuscript, in which he included my name in the acknowledgments section (Paige and Simon 1966).<sup>2</sup> My name in print! And in the same footnote with Allen Newell! So here was a new idea: you could be formally and publicly recognized for your ideas. This was a rush for me. As academics, we forget that we have a unique system of credit assignment, quite unlike the systems in other disciplines. Herb’s simple courtesy of acknowledging, in print, my small improvements to his paper revealed a new source of satisfaction in life: the public attribution of one’s intellectual contributions.

### *Redirections and Deflections*

Curiously, Herb did not have a major influence on my dissertation, beyond the usual support, encouragement, and scholarly advice that one gets from a well-established mentor. The dissertation examined the decision-making structure used by CMU admissions officers. Although my analysis was based in part on some ideas from March and Simon’s

organizations book (March and Simon 1958), the main contribution was to use the newly developed technique of non-metric multi-dimensional scaling (Kruskal 1964) for describing the admissions officers' decision space and how they searched it (Klahr 1969).

However, Herb did play an influential role in a major choice I faced at the end of my graduate years: where to go for my first job. I had narrowed several offers down to two. One was from a top-notch, well-established, research business school: the Graduate School of Business at the University of Chicago. The other was from a college of social science in an exciting, innovative, unconventional, and untested new university: UC Irvine (where, ironically, Jim March had recently moved to build a new Social Science program). Herb helped me to frame my decision in terms of a recently developed thesis that posited two types of academic careers: "cosmopolitans" and "locals" (Gouldner 1957). Under this dichotomy, cosmopolitans make their contributions and achieve their fame through their research, as well as through their activity in national and international professional organizations. Locals, by contrast, tend to be known for their contributions to their own university, through outstanding teaching, program and institutional development, high-level administrative service, and so on. As Herb described it to me, the choice of career type—cosmopolitan or local—had relatively clear consequences and different types of payoffs.

This was typical of Herb: to view theoretical constructs in the behavioral sciences not simply as abstract notions but as useful tools for guiding decision making. For the first time, I saw how such "academic" ideas could produce not only journal articles, but also important life choices. And in characteristic fashion, having structured the decision for me, Herb refused to make a recommendation one way or the other.<sup>3</sup>

But here, I must note that on this point Herb Simon failed to take his own advice; he never chose between being a cosmopolitan or a local because he had the energy and intellectual power to achieve overwhelming success as both. The cosmopolitan record is nothing short of astonishing. For starters there is the Nobel Prize in Economic Sciences,

the National Medal of Science, and membership in the National Academy of Science. In addition, Herb received honorary degrees from two dozen universities around the world, as well as the top research contributions awards from the American Psychological Association, the American Psychological Foundation, the American Psychological Society, the Association for Computing Machinery, the American Economic Association, the American Society of Public Administration, the Academy of Management, the American Political Science Association, the Operations Research Society of America, and the Institute of Management Science. Moreover, he was a member of the Chinese Academy of Sciences and the Automation Hall of Fame at the Chicago Museum of Science and Technology, and an honorary member of the Institute of Electrical and Electronic Engineers. He was also the first social scientist appointed to the President's Science Advisory Committee.<sup>4</sup>

Herb's record as a "local" who came to Carnegie Mellon<sup>5</sup> in 1949 and never left is equally impressive. During the same extended period during which he published the nearly 1,000 articles that made him so famous, he exerted a profound, long-lasting, and intentional influence on his home institution. Herb was both a University Professor—our highest academic honor—and a Life Trustee of the University. In the pursuit of his intellectual goals, Herb created, rearranged, sacked, supported, and integrated many organizational elements within Carnegie Mellon University. As a result, the list of CMU departments that bear his irrevocable and indelible stamp includes not only the Department of Psychology but also the Department of Philosophy, the Department of Social and Decision Sciences, the Graduate School of Industrial Administration, the Heinz School of Public Policy and Management, the School of Computer Science, and, yes, even the Physics Department. Not only do each of these individual units bear the stamp of Herb Simon's creative vision and administrative determination, but also the ethos and nature of the entire university reflect his vision and commitment.

## Reactions

The next example of Herb's influence on me falls into the category of intellectual and scientific influence, rather than personal influence. Via a complex path not worth describing here, my research focus changed, early in my career, to the investigation of cognitive processes in young children. I had begun to collaborate with my colleague Iain Wallace on a project that aimed to characterize young children's thought processes by using the same general approach to cognition as had been developed at CMU by Simon and Newell. One could summarize our research program as an attempt to revisit the questions proposed by Piaget (1968) in terms of the constructs and methods used by Newell and Simon (1972). This required that we move beyond the type of tasks and form of analysis commonly used in developmental psychology.

The work that had immense influence on us was the landmark paper on letter series completion (or rule induction) by Simon and Kotovsky (1963).<sup>6</sup> An important innovation in their approach was to propose several different strategies (implemented as programs) that participants might have used to solve the problems, and then to see which strategies best matched human performance. We took the same general approach with 5-year-old problem solvers. I would have chosen neither this type of problem nor this type of analysis had I not been familiar with the Simon and Kotovsky work.

After working on the project for a while, I noticed a few weaknesses in their paper which I described in an early draft that I sent to Herb. His response was characteristically gracious; he acknowledged that our critiques were valid, but he wondered why they had such an adversarial tone. (Neither Herb nor I would even touch the idea of anything Oedipal going on here!) "Science is cumulative," he wrote in what would have been—from a lesser person—an angry putdown, "and your paper would be stronger if you pointed out how your approach differed from ours and how each approach had specific shortcomings yet to be remedied." Of course we did what he suggested, and thus produced our

first paper in the area of cognitive development (Klahr and Wallace 1970). Having learned the rules of academic protocol from the Master, I was happy to acknowledge Herb's contribution to our paper in a footnote, although in what now strikes me as an unnecessarily ungracious way: "We are most grateful to Professor H. A. Simon," our footnote said, "for his critical comments on an earlier version of this paper, not all of which we have heeded." (Perhaps I can excuse the unmannerly tone here by blaming it on my having been around too many economists during my graduate school days.)

### *Reabsorption*

Shortly thereafter, I received an invitation to return to GSIA to work on problems of applying cognitive psychology principles to the GSIA education process. Herb had convinced Richard Cyert (then the Dean of GSIA) that cognitive psychology had reached the point where it could be applied to the design of more effective managerial instruction and had convinced the Ford Foundation to support the effort lavishly. The main attraction for me was the chance to have Simon and Newell as colleagues, and to return to an intellectual environment that was unique in the world and precisely suited to my needs and interests.

Like many of Herb's ideas, the concept of a "learning engineer"—someone who could translate basic principles from the science of cognitive psychology to the creation of more effective instructional systems—was well ahead of its time.<sup>7</sup> After I returned to GSIA in 1969, the idea was instantiated in what now look like quite mundane activities such as the creation of instructional video tapes, teacher evaluation instruments, and well-defined cognitive objectives for courses. But I was excited at the idea of becoming the "point man" for such an idea, and flattered to be invited back to Cognitive Mecca by two of the icons of my graduate school days: Cyert and Simon.

Nevertheless, at the time, I couldn't see how the "learning engineering" had much relevance to my increasing interest in information

processing models of children's thinking, so we arranged a somewhat unusual effort allocation. My work on the GSIA teaching issues would comprise my teaching load and I would be free to pursue my developmental interests as my research agenda. I would also have an appointment in the psychology department, where Herb had recently taken up permanent residence, after moving his office out of GSIA.

### *Equilibrium*

I will condense the next 25 years by posing a question: How can a young investigator carve out an independent scientific career when in the same department with a prior mentor who maintains a vigorous, prolific, and highly visible world-class research program well into his eighties? My answer was to create a comfortable distance from Herb by situating my work in a niche in cognitive psychology into which Herb had never bothered to wander: cognitive development.<sup>8</sup> For many years I continued to work on information processing models of cognitive development (Klahr and Wallace 1976; Klahr 1992). But this too was a dynamic equilibrium, with the need for distance countered by the obvious relevance of the work of Simon and Newell, and of Herb's specific interest in the psychology of scientific discovery. Only when I was beyond my own 60th birthday did I feel secure enough in my own expertise to finally collaborate with Herb on a paper that reviewed the area representing the intersection of our mutual interest in scientific thinking in adults and children (Klahr and Simon 1999). Although this collaboration was one of the most satisfying experiences of my career, it saddens me still to recall that, on the day that the proofs for a brief report on that project (Klahr and Simon 2001) appeared in my mailbox, I learned that Herb had died.

This need to find an equilibrium position with respect to Herb's ideas and influence was also manifest during the 10 years that I served as head of the Department of Psychology (1983–1993). From the outset, I felt that my responsibility was to treat each faculty member and each area in the department with equal respect and consideration, rather

than to implement Herb's agenda. Thus, before accepting the position, I met with Herb and told him that if I became head of the department, I would not continue the regular private meetings with him that previous department heads had held to discuss departmental business. Once again, Herb's grace, civility, and sense of fair play prevailed. He just gave me a mischievous smile and said that would leave him even more time for his research meetings.

This is not to suggest that, either during the period of my headship or for the nine years thereafter, Herb suspended his vigorous promotion of the ideas and decisions that he thought were the right ones for the department. Quite the contrary, for he remained an active participant in departmental decisions up to the end. Herb was strong willed, brilliant, tenacious, and aggressive when he wanted to be, but he was a "mensch" at all times, and he knew what fair play, decency, and integrity meant.

Having said that, I must acknowledge my uneasiness at praising Herb Simon's character! I'm sure it would embarrass and perhaps annoy him to read the many plaudits in this chapter and this volume. He was uncomfortable around groupies and acolytes. He once dismissed his seemingly endless list of awards and honorary degrees by telling me that "after a while the criterion for getting an honor is to have been awarded a lot of other honors." And so it must have seemed to him as he garnered dozens of awards, any one of which would have been cherished by most of us.

For Herb, the real rewards were in the discovery, the solved problem, the novel idea, the deep insight, the published paper, the citation, and the work that his work spawned. What he didn't like was being told, directly, that he was one hell of a guy. The following story, taken from the introduction to a Simon festschrift that Ken Kotovsky and I organized, illustrates the point:

Early in our careers, both of us had the privilege of having Herb as our dissertation advisor, and we are both deeply indebted to him for the kind of values, skills, and attitudes that such an apprenticeship inculcates. Another thing we both learned long ago was to respect the dual-edged sword of Herb's

rapid insight and equally rapid impatience with poor ideas. . . . Thus, even two decades beyond our graduate student days, it was with some trepidation that we approached him with our plan for this volume. Would the whole idea strike him as tangential to the real business of science? . . . his general reaction was supportive, but he had two requests. First, he would not be a passive participant in his own *Festschrift*; at the age of 71, as always, the research was his focus and priority: and he wanted to present a paper on his current research program at the symposium. Of course, we were delighted with that idea, and we agreed. Second, he wanted us to instruct the other participants to "avoid hagiography." We agreed to that too. And so we left his office with his blessings, and without the slightest idea about what 'hagiography' meant.<sup>9</sup> (It was not the first time that we had left his office concealing our ignorance and scurrying off to remedy it.) (Klahr and Kotovsky 1989, p. xvi)

Although Herb was always uncomfortable with acolytes, he was certainly not a distant, cool person. He could write as eloquently about love and meaning as about goals and problem spaces. As he put it (1965, p. 110):

Man is a problem-solving, skill-using, social animal. Once he has satisfied his hunger, two main kinds of experiences are significant to him. One of his deepest needs is to apply his skills, whatever they be, to challenging tasks—to feel the exhilaration of the well-struck ball or the well-solved problem. The other need is to find meaningful and warm relations with a few other human beings—to love and be loved, to share experience, to respect and be respected, to work in common tasks.

Over the years, his colleagues in the department made it very clear to him that he was indeed in the company of those who shared experience with him, who respected him and valued his respect, and who worked on common tasks. One particularly warm occasion was on Herb's seventieth birthday. I was head of the department at the time, and I decided to create a design for his birthday cake that could somehow represent one of his contributions to the field. I labored for a few hours and came up with "Herb's EPAM birthday cake." EPAM (Elementary Perceiver And Memorizer) was a pioneering computational model of memory and retrieval that Herb developed with Ed Feigenbaum (Simon and Feigenbaum 1964); he continued to extend

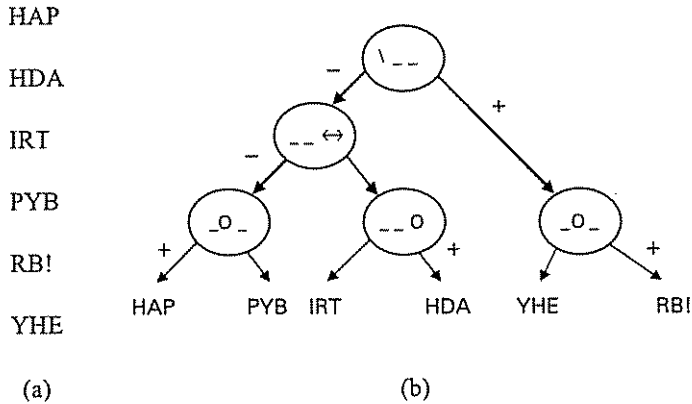

**Figure 1**

An EPAM discrimination net for sorting letter triads for Herbert Simon's 70th-birthday greeting. (a) Letter triads. (b) Discrimination net.

and develop it to the end of his life (Gobet, Richman, Staszewski, and Simon 1997; Richman, Staszewski, and Simon 1995). The design on the cake was an EPAM discrimination net that sorted the letters of the birthday greeting down to the terminal nodes. The tests were for features of letters in specific positions of a set of letter triads. For example, the node `_O_` tests a triad for a closed curve in the letter in the center position, and `--↔` tests for symmetry in the right-most letter in the triad. The triads are shown, in alphabetical order on the left of figure 1, and the EPAM tree is shown on the right. Designing this cake is the kind of project that my teenage children would call "dorky," but Herb's cheerful reception made it clear that he appreciated the fondness with which it was offered.

### High Energy

I have yet to convey the energy that emanated from this man. You couldn't escape it: in the intensity with which he listened to your ideas, in the excitement with which he described his own most active project, or in the way he attacked even the most mundane everyday puzzles.

Let me illustrate with an example from the last category. About 25 years ago, Herb and I and a few other colleagues were returning from a conference that had concluded in a late spring snowstorm that led to several muddled airline connections. At the end of it all, we wound up flying from Denver to Cleveland, and then driving to Pittsburgh at 1 A.M. I was at the wheel. (I thought Herb was too old to drive at that late hour, but he was younger then than I am now!) It had been a long day, and we were all tired. Conversation waned. I muttered something about how the roads were pretty deserted. Oops, that did it.

"Hmmm," said Herb: "I wonder what the density of cars on the interstates is right now. How many cars in the US? What proportion might be on the road at 1 A.M.? Well, let's see: How many linear miles of interstate? Assume the US is a rectangle 2,500 miles long by 1,200 miles wide. Estimate that there the interstates are distributed on a grid, with the east-west routes approximately every 200 miles apart and the north-south routes approximately 300 miles apart." And so it went. I did *not* fall asleep at the wheel. The man never stopped thinking. Ideas were his passion.

### *Binding Forces*

I have attempted to summarize the dynamics of more than 40 years of interaction with Herb Simon, from a distant intellectual attraction to a close colleagueship. By the time I had approached my sixties and Herb his eighties, I had become sufficiently close to him and confident of our relationship to converse comfortably about personal as well as professional issues. In one particularly revealing episode, we were exchanging e-mail messages about a book by Calvin Trillin that I had given to Herb during his recuperation from heart surgery. Trillin (1996) describes his experiences as an assimilated Jew growing up in the Midwest, as well as his attempt to figure out what kind of "messages" about life his father attempted to convey to him. The book, and his recovery, led Herb to talk about two things he had never mentioned to me before and about

which he had only written briefly in his autobiography: his father and his Judaism.

I'll let Herb close this chapter in his own words, so characteristically intelligent, articulate, curious, funny, honest, and humane:

Feb. 20 1998

Dear Dave,

On medical matters, angina sooner or later ends in a heart attack (if the blood flow is blocked) or a stroke (if the blood pressure gets too high before the flow stops entirely). My angina having reached the point where I could no longer walk comfortably back and forth to school, I had the appropriate x-rays made (I have a great picture of the coronary artery and its branches; looks just like an EPAM net) and, on the basis of the evidence, decided that it was time to act. There are two kinds of by-pass, depending on where the blockage is. In the first, they have to actually stop the heart and pump blood artificially during much of the operation. That isn't a great idea for people at age 81, and frequently fatal. In the second, which fortunately was my case, the blockage was located so that they could make the graft (from the mammary artery!) without stopping the heart—not terribly dangerous at all. I feel great (far better than before the operation), and everything seems to be continuing smoothly.

That's your medical lesson for today.

Thank you very much for the Trillin book, which I have read, and found very moving. Dot is reading it at present. Reading such a book invites comparison with one's own life. My father, like Trillin's, was a very private person, and if he had any ambitions for me, he never communicated them, nor did I discover before he died (when I was about 32) whether I had followed a path he expected—although he seemed quite satisfied with my academic career, and the facts that I kept out of jail and paid my bills without too much dependence on him. If he secretly wanted me (or my brother) to be an engineer or a farmer, or any more esoteric thing that he himself aspired to, I never had any inkling, although I myself found my approach toward engineering (during my Operations Research days) to bring me closer to him in an unexpected way.

The other interesting theme of the book was the gradual assimilation of a Jewish family. In my case, it had happened a generation earlier, for both my father and my mother had lost any religious attachment to Judaism. Yet the Jewish background of my family on both sides made me identify with those origins and influenced me in very deep ways.

Dot and I, as devoted *New Yorker* readers (until the new regime came along five or ten years ago), read a number of Trillin's tales about midwestern towns,

but somehow, his name never stuck in our minds, or had somehow been washed away, until you sent the book.

Thanks very much. It was a great way to keep my mind off my troubles when I came home from the hospital a week ago. (Although I must confess that I have had almost zero troubles, including no pain or complications, and an immediate relief from the angina whose progress had gradually convinced me, over the past several years, that this plumbing job was necessary.)

I'm going to indulge myself in another three weeks' or so of house arrest, and then I'll be back to roam the Baker Halls in my usual way.

Warm regards,  
Herb

Herb Simon died three years later from surgical complications unrelated to his successful bypass operation. The Force is gone, but not the forces. His monumental intellectual achievements will continue to shape not only the dozens of fields to which he directed his attention, but also the paths of many hundreds of colleagues who were fortunate enough to interact with him, and through them, thousands of others. I hope that in my own small way, I can influence the personal, professional and scientific trajectories of a few others in the way that Herb Simon influenced mine. I owe him that, at the least.

## Notes

1. It has a reasonable claim on four Nobel laureates in economics—including Herb—who started their careers there. The others are Franco Modigliani, Merton Miller, and Robert Lucas.
2. This paper appeared in the first Carnegie Symposium on Cognition. This first volume on problem solving (Kleinmuntz 1966) includes, in addition to the CMU participants, chapters by B. F. Skinner, R. Gagné, and D. E. Berlyne, among others.
3. Although I was quite tempted by the unorthodox organization of the new university, I decided to take the more conservative route.
4. A more complete record of Herb's awards and accomplishments is available at <http://www.psy.cmu.edu>. His own description of his remarkable life can be found in his autobiography (Simon 1991). For a fascinating account of his role in the "cognitive revolution," see McCorduck 1979.

5. More precisely, to the Carnegie Institute of Technology (CIT). Carnegie Mellon University founded in 1965 with the merger of CIT and the Mellon Institute.
6. This paper is of historical as well as scientific interest because it was the first ever to create a computational model for a high level cognitive task and compare the model's performance to human behavior.
7. I believe that only in the past dozen years or so has this idea been realized through the creation of theoretically grounded and widely disseminated cognitive tutors (cf. Corbett, Anderson, and Patterson 1990; Koedinger, Anderson, Hadley, and Mark 1997; Singley, Anderson, Gevins, and Hoffman 1989).
8. An overstatement, I must admit. Herb had, in fact, written one extremely insightful paper about the relationship between issues in cognitive development and the emerging area of information processing psychology (Simon 1962). Lucky for me, he chose not to do any further work in the area.
9. It means the writing and critical study of the lives of the saints.

## References

- Corbett, A. T., Anderson, J. R., and Patterson, E. G. 1990. Student modeling and tutoring flexibility in the LISP intelligent tutoring system. In C. Frasson and G. Gauthier, eds., *Intelligent Tutoring Systems*. Ablex.
- Cyert, R. M., and March, J. G. 1963. *A Behavioral Theory of the Firm*. Prentice-Hall.
- Gobet, F., Richman, H. B., Staszewski, J. J., and Simon, H. A. 1997. Goals, representations and strategies in a concept attainment task: The EPAM model. *Psychology of Learning and Motivation* 37: 265–290.
- Gouldner, A. W. 1957. Cosmopolitans and Locals: Toward an Analysis of Latent Social Roles—I. *Administrative Science Quarterly* 2, no. 3: 281–306.
- Klahr, D. 1969. Decision making in a complex environment. *Management Science* 15: 595–618.
- Klahr, D. 1992. Information processing approaches to cognitive development. In M. Bornstein and M. Lamb, eds., *Developmental Psychology*, third edition. Erlbaum.
- Klahr, D., and Kotovsky, K., eds. 1989. *Complex Information Processing: The Impact of Herbert A. Simon*. Erlbaum.
- Klahr, D., and Simon, H. A. 1999. Studies of scientific discovery: Complementary approaches and convergent findings. *Psychological Bulletin* 125, no. 5: 524–543.

- Klahr, D., and Simon, H. A. 2001. What have psychologists (and others) discovered about the psychology of scientific discovery? *Current Directions in Psychological Science* 10, no. 3: 75–83.
- Klahr, D., and Wallace, J. G. 1970. The development of serial completion strategies: An information processing analysis. *British Journal of Psychology* 61: 243–257.
- Klahr, D., and Wallace, J. G. 1976. *Cognitive Development: An Information Processing View*. Erlbaum.
- Kleinmuntz, B., ed. 1966. *Problem Solving: Research, Method and Theory*. Wiley.
- Koedinger, K. R., Anderson, J. R., Hadley, W. H., and Mark, M. 1997. Intelligent tutoring goes to school in the big city. *International Journal of Artificial Intelligence in Education* 8: 30–43.
- Kruskal, J. B. 1964. Multidimensional scaling by optimizing goodness of fit to a non-metric hypothesis. *Psychometrika* 29: 1–27.
- March, J. G., and Simon, H. A. 1958. *Organizations*. Wiley.
- McCorduck, P. 1979. *Machines Who Think*. Freeman.
- Newell, A., and Simon, H. A. 1956. The logic theory machine. *IRE Transactions on Information Theory* IT-2(3): 61–79.
- Newell, A., and Simon, H. A. 1972. *Human Problem Solving*. Prentice-Hall.
- Newell, A., Shaw, J. C., and Simon, H. A. 1958. Elements of a theory of human problem solving. *Psychological Review* 65: 151–166.
- Paige, J. M., and Simon, H. A. 1966. Cognitive processes in solving algebra word problems. In B. Kleinmuntz, ed., *Problem Solving*. Wiley.
- Piaget, J. 1968. Quantification, conservation and nativism. *Science* 162: 976–979.
- Richman, H. B., Staszewski, J. J., and Simon, H. A. 1995. Simulation of expert memory using EPAM IV. *Psychological Review* 102, no. 2: 305–330.
- Simon, H. A. 1962. An information processing theory of intellectual development. In W. Kessen and C. Kuhlman, eds., *Thought in the Young Child*. Monographs of the Society for Research in Child Development, serial no. 83.
- Simon, H. A. 1965. *The Shape of Automation for Men and Management*. Harper and Row.
- Simon, H. A. 1991. *Models of My Life*. Basic Books.
- Simon, H. A., and Feigenbaum, E. A. 1964. An information-processing theory of some effects of similarity, familiarization, and meaningfulness in verbal learning. *Journal of Verbal Learning and Verbal Behavior* 3: 385–396.

Simon, H. A., and Kotovksy, K. 1963. Human acquisition of concepts for sequential patterns. *Psychological Review* 70: 534–546.

Simon, H. A., and Newell, A. 1958. Heuristic problem solving: The next advance in operations research. *Operations Research* 6: 1–10

Singley, M. K., Anderson, J. R., Gevins, J. S., and Hoffman, D. 1989. The algebra word problem tutor. In D. Bierman et al., eds, *Artificial Intelligence: Synthesis and Reflection*. IOS.

Trillin, C. 1996. *Messages from My Father*. Farrar, Straus and Giroux.